

# Technické frézy tvrdokovové Tungsten Carbide Burrs

## VÁLCOVÁ CYLINDER

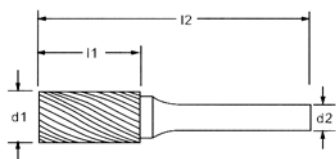
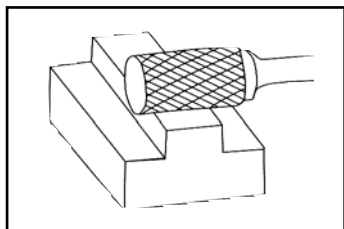

Označení Item No.	d1	d2	l1	l2
A0314T03	3	3	14	38
A0413T03	4	3	13	52
A0513T03	5	3	13	52
A0613T03	6	3	13	53
A0618T06	8	6	18	63
A0818T06	8	6	18	63
A1020T06	10	6	20	65
A1225T06	12	6	25	70
A1625T06	16	6	25	70
A1925T06	19	6	25	70

## VÁLCOVÁ S ČELNÍM BŘÍTEM CYLINDER END CUT

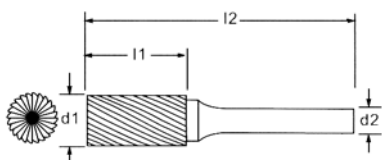
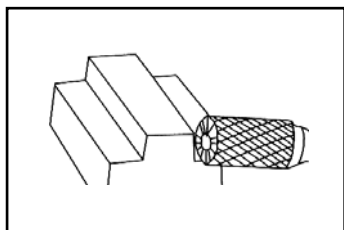

Označení Item No.	d1	d2	l1	l2
B0314T03	3	3	14	38
B0613T03	6	3	13	52
B0618T06	6	6	18	63
B0818T06	8	6	18	63
B1020T06	10	6	20	65
B1225T06	12	6	25	70
B1625T06	18	6	25	70
B1925T06	19	6	25	70

## VÁLCOVÁ S RÁDIUSEM CYLINDER WITH BALL TOP

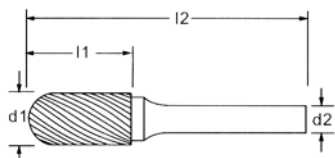
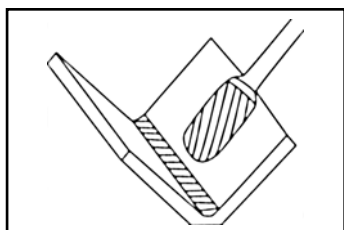

Označení Item No.	d1	d2	l1	l2
C0314T03	3	3	14	35
C0512T03	5	3	12	52
C0613T03	6	3	13	53
C0618T06	6	6	18	63
C0818T06	8	6	18	63
C1020T06	10	6	20	65
C1225T06	12	6	25	70
C1625T06	16	6	25	70
C1925T06	19	6	25	70

# Technické frézy tvrdokovové Tungsten Carbide Burrs

Označení Item No.	d1	d2	l1	l2
D0303T03	3	3	3	38
D0403T03	4	3	3	43
D0504T03	5	3	4	44
D0605T06	6	6	5	50
D0807T06	8	6	7	52
D1009T06	10	6	9	54
D1211T06	12	6	11	56
D1614T06	16	6	14	60
D1917T06	19	6	16	62

## KULOVÁ BALL SHAPE

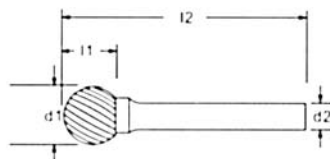
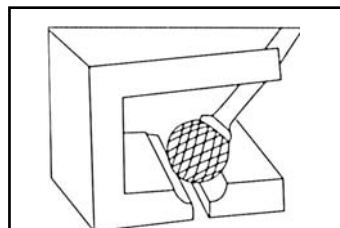

Označení Item No.	d1	d2	l1	l2
E0306T03	3	3	6	38
E0508T03	5	3	8	48
E0610T03	6	3	10	50
E0610T06	6	6	10	55
E0813T06	8	6	13	58
E1016T06	10	6	16	61
E1220T06	12	6	20	65
E1625T06	16	6	25	70
E1925T06	19	6	25	70

## ELIPTICKÁ ELLIPSE

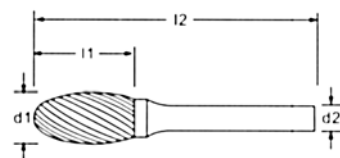
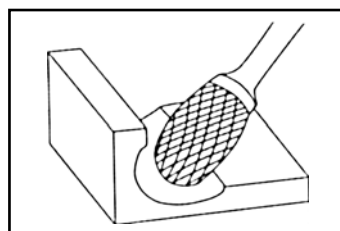

Označení Item No.	d1	d2	l1	l2
F0313T03	3	3	13	38
F0513T03	5	3	13	50
F0613T03	6	3	13	53
F0618T06	6	6	18	63
F0818T06	8	6	18	63
F1020T06	10	6	20	65
F1225T06	12	6	25	70
F1625T06	16	6	25	70
F1925T06	19	6	25	70
F1932T06	19	6	32	77

## STROMEČKOVÁ S RÁDIUSEM ARC CYLINDER WITH BALL TOP

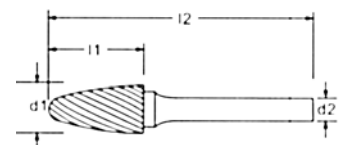
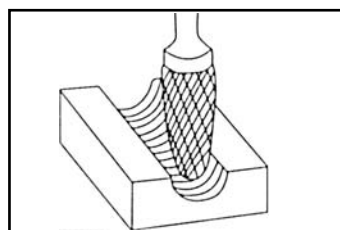

## STROMEČKOVÁ SE ŠPIČKOU ARC CYLINDER WITH SHARP TOP

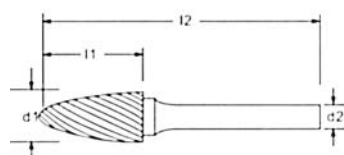
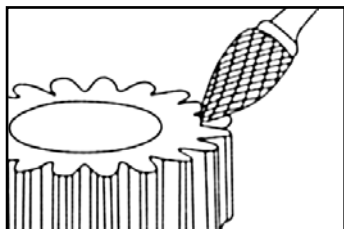

Označení Item No.	d1	d2	l1	l2
G0313T03	3	3	13	38
G0613T03	6	3	13	53
G0618T06	6	6	18	63
G0818T06	8	6	18	63
G0820T06	8	6	20	65
G1020T06	10	6	20	65
G1220T06	12	6	20	65
G1225T06	12	6	25	70
G1625T06	16	6	25	70

## PLAMĚNKOVÁ FLAME

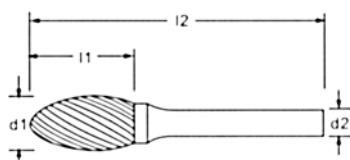
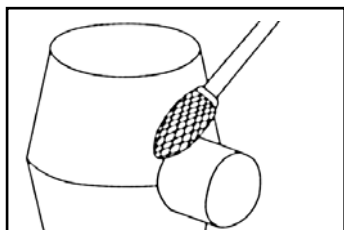

Označení Item No.	d1	d2	l1	l2
H0307T03	3	3	7	47
H0618T06	6	6	18	63
H0820T06	8	6	20	65
H1025Z06	10	6	25	70
H1232T06	12	6	32	75
H1636T06	16	6	36	81
H1941T06	19	6	41	86

## ZÁHLUBNÍK 60° CONE 60°

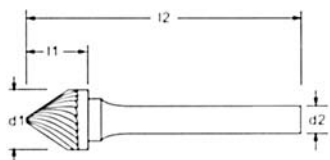
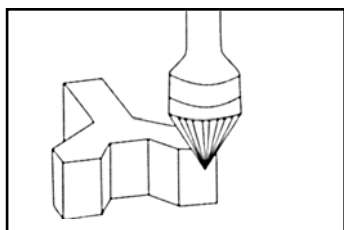

Označení Item No.	d1	d2	l1	l2
J0303T03	3	3	2,5	38
J0605T06	6	6	5	50
J0807T06	8	6	7	52
J1008T06	10	6	8	54
J1210T06	12	6	10	55
J1614T06	16	6	14	59
J1916T06	19	6	16,5	65

# Technické frézy tvrdokovové Tungsten Carbide Burrs

Označení Item No.	d1	d2	l1	l2
L0313T03	3(14°)	3	13	38
L0513T03	5(14°)	3	13	38
L0612T03	6(14°)	3	12	38
L0619T03	6(14°)	3	19	38
L0612T06	6(14°)	6	12	38
L0616T06	6(14°)	6	16	61
L0822T06	8(14°)	6	22	67
L1027T06	10(14°)	6	27	72
L1230T06	12(14°)	6	30	75
L1630T06	16(14°)	6	30	75
L1938T06	19(14°)	6	38	83

## KUŽELOVÁ S RÁDIUSEM CONICAL ROUND NOSE

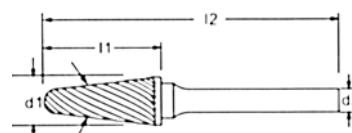
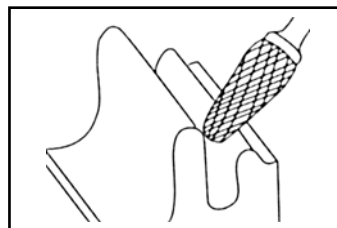

Označení Item No.	d1	d2	l1	l2
M0311T03	3(14°)	3	11	38
M0316T03	3(7°)	3	16	38
M0513T03	5(14°)	3	12,7	38
M0613T06	6(22°)	6	12,7	50
M0619T06	6(14°)	6	19	64
M0818T06	8(25°)	6	18	63
M0820T06	8(22,6°)	6	20	65
M1016T06	9,5(28°)	6	16	61
M1020T06	10(25°)	6	20	65
M1225T06	12(25°)	6	25	70
M1625T06	16(36°)	6	25	70

## KUŽELOVÁ CONE SHAPE

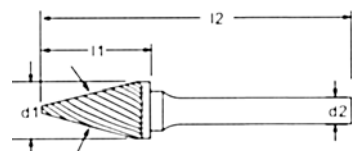
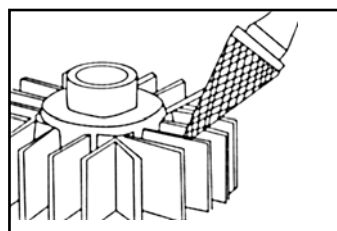

Označení Item No.	d1	d2	l1	l2
K0302T03	3	3	1,5	38
K0603T06	6	6	3	48
K0804T06	8	6	4	49
K1005T06	10	6	4,7	50
K1206T06	12	6	6	51
K1608T06	16	6	8	53
K1910T06	19	6	9,5	55

## ZÁHLUBNÍK 90° CONE 90°

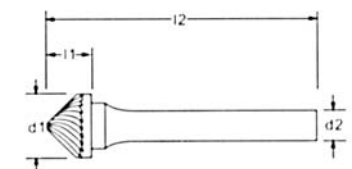
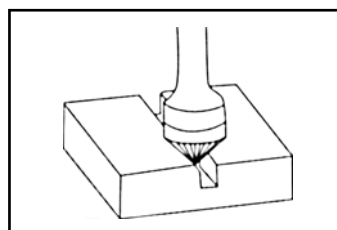

## OBRÁCENÝ KUŽEL INVERTED CONE

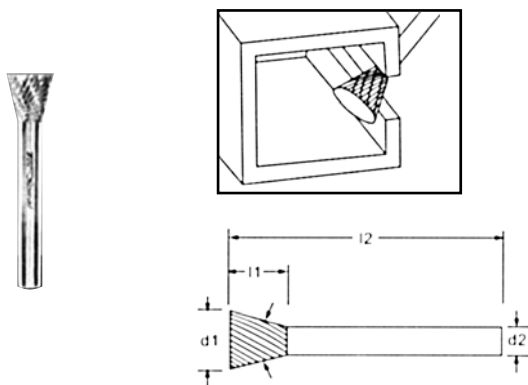

Označení Item No.	d1	d2	l1	l2
N0303T03	3(10°)	3	3	40
N0304T03	3(10°)	3	4	40
N0505T03	5(10°)	3	5	45
N0608T06	6(10°)	6	8	53
N0606T03	6,3(10°)	3	6	46
N1010T06	9,5(13°)	6	9,5	55
N1313T06	12,7(28°)	6	12,7	58
N1619T06	16(20°)	6	19	61
N1916T06	19(30°)	6	16	61

## DISKOVÝ TVAR S RÁDIUSEM DISC TYPE WITH ARC EDGE

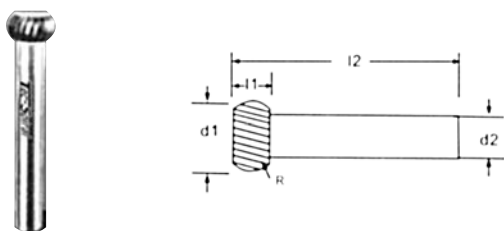

Označení Item No.	d1	d2	l1	l2	R
W1603T06	16	6	3	45	2,5
W2504T06	25	6	4	45	4
W2505T06	25	6	5	45	4

## DISKOVÝ TVAR DISC TYPE

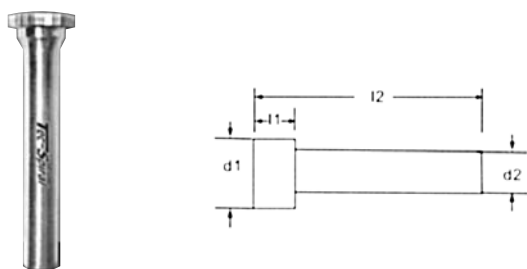

Označení Item No.	d1	d2	l1	l2
X1202T06	12	6	2	45
X1602T06	16	6	2	45
X1603T06	16	6	3	45
X2504T06	25	6	4	45
X2505T06	25	6	5	45

## DISKOVÝ TVAR S 90° ÚHLEM DISC TYPE WITH 90° ANGLE

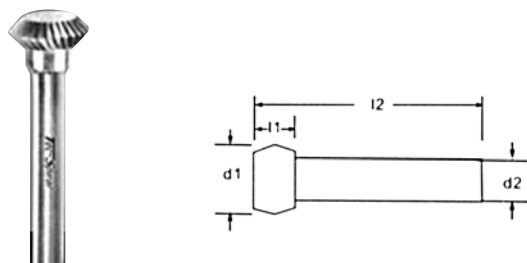

Označení Item No.	d1	d2	l1	l2
Y1603T06	16	6	3	45
Y2505T06	25	6	5	45

# Technické frézy tvrdokovové Tungsten Carbide Burrs



T = X

Y

V

M

W

wide cut - jednoduchý široký břit

single cut - jednoduchý břit

speed way - jemný křížový břit

cheap breaker - s lamačem třísek

double cut - křížový břit

Příklad objednávky (Order):

F1225X06

Fréza stromečková s rádiusem, délka řezné části 12 mm, stopka 6 mm, křížový břit (X)  
ARC CYLINDER WITH BALL TOP, d1=12 mm, d2=6mm, double cut (X)

**ProFitex**  
[www.profitexsk.com](http://www.profitexsk.com)

Telefón: 0948/303419

E-mail: [profitexsk@gmail.com](mailto:profitexsk@gmail.com)